

PHILIPP GROUP

PHILIPP Spherical head double-headed anchor

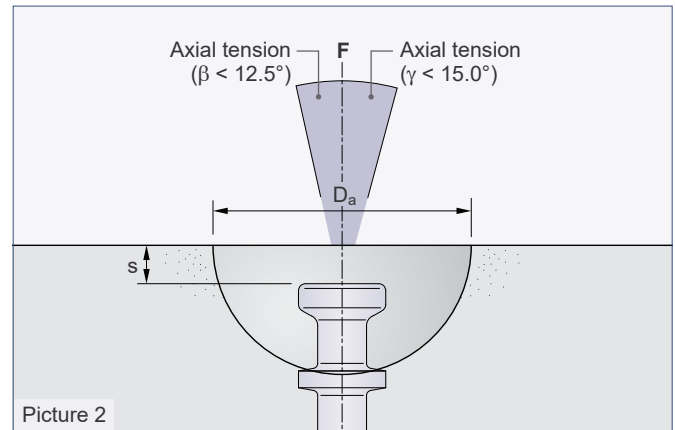

PHILIPP Spherical head double-headed anchor

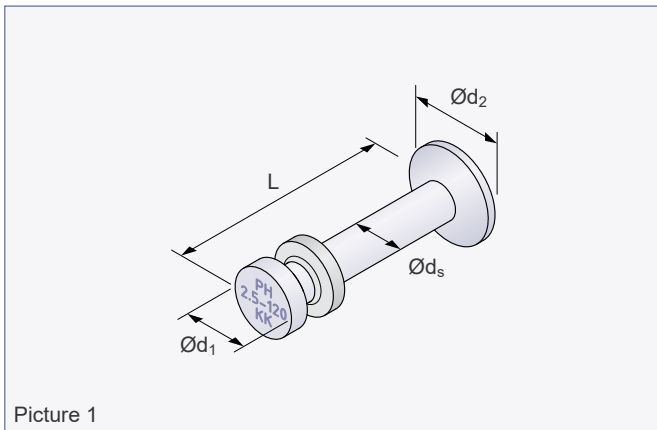

The Spherical head double-headed anchor is part of the PHILIPP transport anchor system. Its use requires also the compliance with the Installation Instruction for the belonging lifting device (Lifting clutch). The anchor may only be used in combination with the mentioned PHILIPP lifting devices.

Depending on the individual application it might be necessary to contact our technical department.

The Spherical head double-headed anchor is fixed with recess formers (83-AKS-___ oder 83-AKM-___) to the mould before concreting.

Table 1: Dimensions of the Spherical head double-headed anchor

Ref.-No.	Type	perm. F ① [kN]	Dimensions						Weight [kg/100 pcs.]
			L [mm]	Ød _s [mm]	Ød ₁ [mm]	Ød ₂ [mm]	s [mm]	D _a [mm]	
81-013-040MA	KK 1,3	13.0	40	10	18	25	10	60	60,0
81-013-050MA	KK 1,3	13.0	50	10	18	25	10	60	70,0
81-013-065MA	KK 1,3	13.0	65	10	18	25	10	60	80,0
81-013-085MA	KK 1,3	13.0	85	10	18	25	10	60	80,0
81-025-065MA	KK 2,5	25.0	65	14	25	35	11	74	130,0
81-025-085MA	KK 2,5	25.0	85	14	25	35	11	74	160,0
81-025-120MA	KK 2,5	25.0	120	14	25	35	11	74	210,0

① Load bearing capacity of steel for axial tension.

Dimensions and load classes

In order to distinguish the different sizes of Spherical head double-headed anchors a marking with load class and length is given on the head of the anchor. Dimensions and load classes of the Spherical head double-headed anchors are given in table 1 and picture 1.

Materials

The Spherical head double headed anchor is made of special round steel bar material. Besides the standard version in black steel the anchors can be supplied also in electro-galvanised or stainless steel material.

Corrosion

If the concrete elements with installed Spherical head double-headed anchors are stored outside for a longer time (contact with rain or humidity causes moisture insight the recesses) corrosion may reduce the bearing capacity of the Spherical head double-headed anchor. Therefore the anchor may fail under load. In addition, marks on the concrete surface caused by corrosion may appear.

i The EC Declaration of Conformity (DoC) of the Spherical head double-headed anchors is available on request or can be downloaded from our website www.philipp-group.de.

